

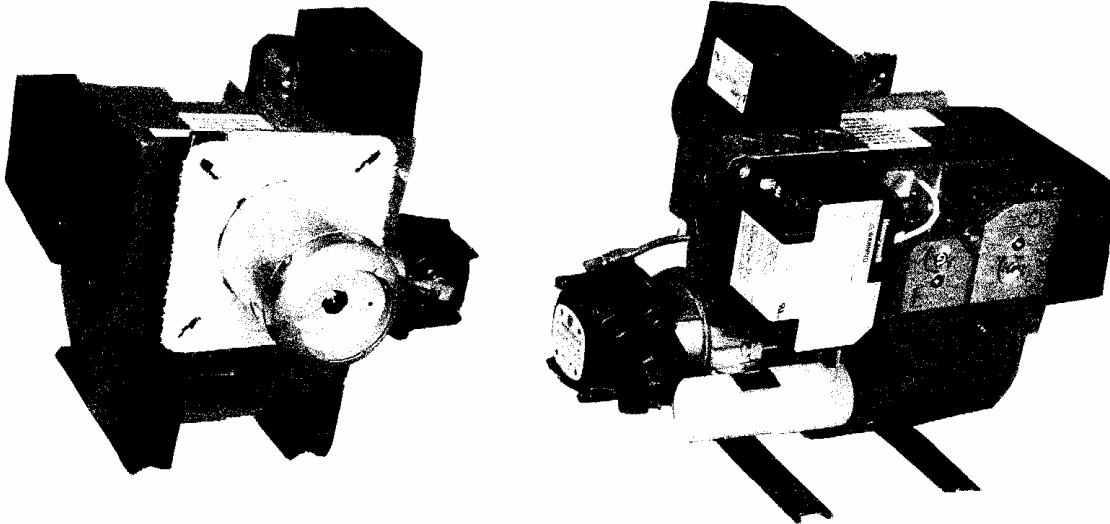

OPERATING INSTRUCTIONS FOR Model PIONEER-1 and PIONEER-2 Burners

CAUTION: For your safety do not store or use gasoline or other flammable vapors and liquids in the vicinity of this unit.

No.2 Fuel oil firing range 0.5 – 4.0 GPH (US)
Units of No.1 or NO.2 oil (ASTM D396)



**Manufactured by Heat Wise, Inc.,
28 Industrial Blvd., Unit I, Medford, NY 11763**



NY City MEA 226-99-E

Table 1: Burner Specifications

Burner Models	Burner Head	Burner Fan	Firing Range in GPH(US)		Optional items
Pioneer 1	FV	3.8" X 1.65"	0.5 to 0.75		Outside air attachment*
	KA	4.7" X 1.65"	0.5 to 1.10		
Pioneer 2	KA	5.75" X 2"	Min.	Max.	High/Low
			1.0	2.75	
	K	5.75" X 2"	1.75	4.0	

*Outside air attachment can be minimum 3" Dia. X 20' nominal pipe with 4 elbows, with each elbow counting as 3'.

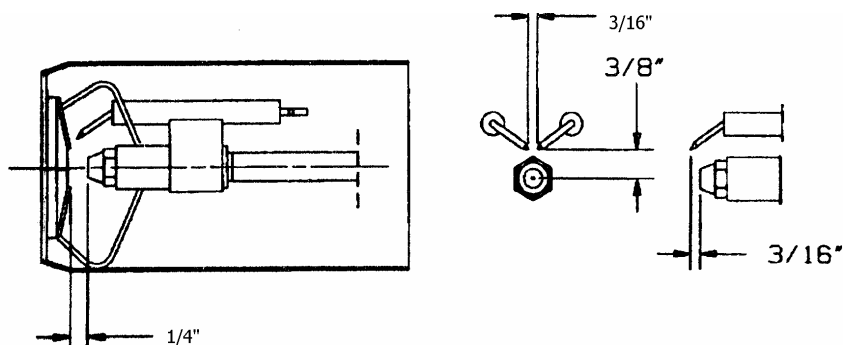
Fig. 1 Electrode Assembly

1. NOZZLE INSTALLATION

1.1 To service the nozzle, unscrew the burner housing bolt using a 4mm allen key and gently pull on the burner to split it into two sections. The nozzle line assembly and burner interior is now exposed for servicing (see Fig. 2).

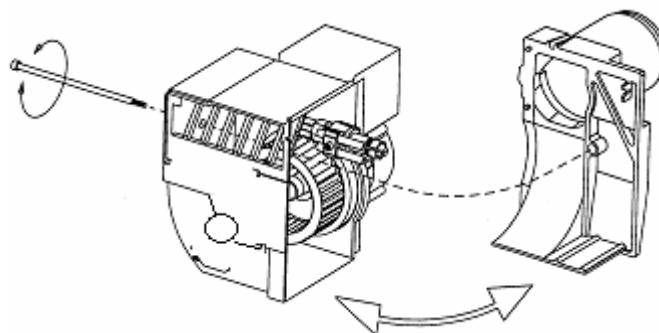
Fig. 2 Nozzle Installation

1.2 The Pioneer series of burners comes with three unique flame retention heads: the **FV**, **K** and **KA**. The type of head is noted on the label on top of the housing. See Picture 1 for pictures of the different heads. Follow the directions below for each head:

Picture 1: FV, K and KA Heads

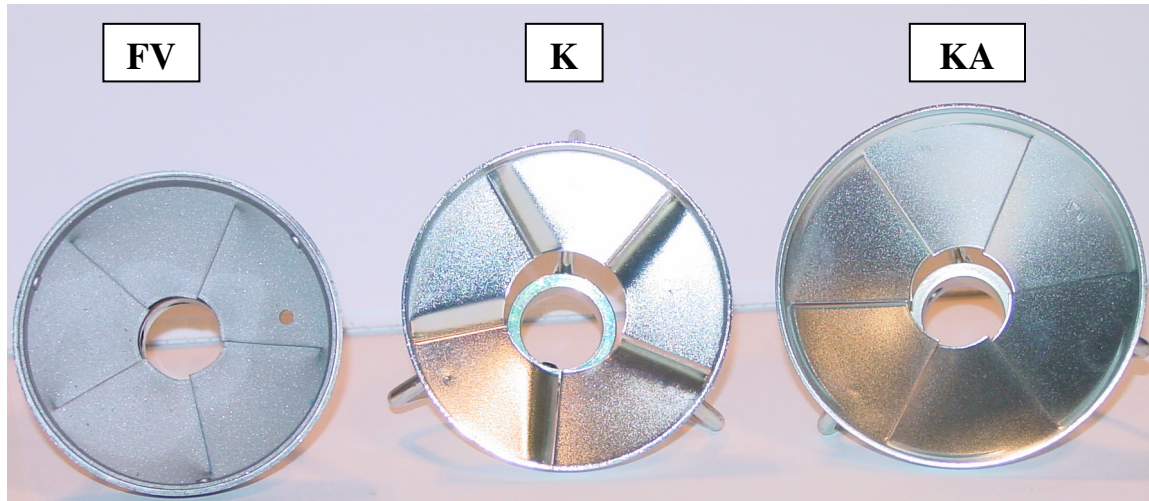

Picture 2: "FV" Head

Using a 4mm allen key, loosen the retention head screw and separate the retention head and electrode assembly from the nozzle line. Remember to disconnect the rajah connector from the electrode assembly. Using two 5/8" wrenches, remove the nozzle from the nozzle line adapter. Install a new nozzle and follows the steps in reverse order to reinstall the burner. NOTE: With the FV head, it is not necessary to disturb the electrodes when servicing the nozzle.



Note: It is important to use two 5/8" wrenches to prevent disorientation and damage to the nozzle assembly.

K and KA Head

The procedure for removing the nozzle is the same for the **K** and **KA** heads. Note the head on the label on the top of the burner housing.

Loosen the retention head screw and the electrode assembly screw by using a 3mm allen key and a 4mm allen key respectively. Remove the rajah connector from the electrode assembly and remove the retention head and electrode assembly at the same time. Using two 5/8" wrenches, remove the nozzle from the nozzle line adapter. Install a new nozzle and follows the steps in reverse order to reinstall the burner. When replacing the ignition electrodes, make sure that they do not rest against the cad cell. **Caution: Do not over tighten the electrode bracket, as this may cause the electrodes to crack.**

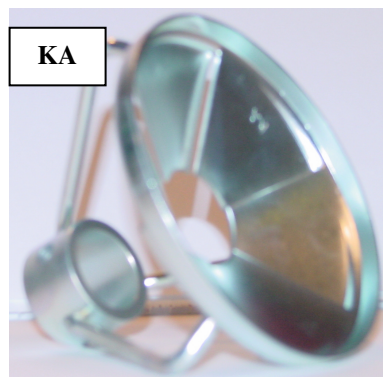
Picture 3: “K” Head**Picture 4: “KA” Head**

Note: It is important to use two 5/8” wrenches to prevent disorientation and damage to the nozzle assembly.

2. WIRING THE BURNER

2.1 This burner is supplied with either the Honeywell or CCT microprocessor control. Follow the wiring diagram shown in Fig. 3 through Fig. 7. All the wiring should conform to the National Electric Code (NEC) or the legally authorized code governing your locality. When wiring, be sure that the electric power take-off is disconnected from the live circuit. **The power supply must have a 15-amp circuit breaker or fuse with a service switch located not more than 3 feet from the burner.**

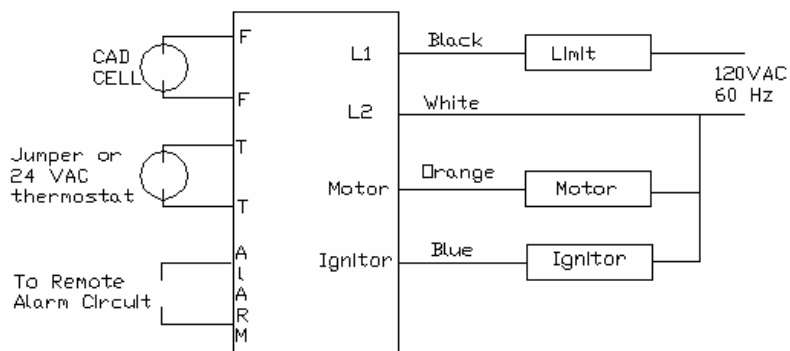
Fig. 3 Wiring Diagram - Standard

Honeywell R7184B & Carlin 40200

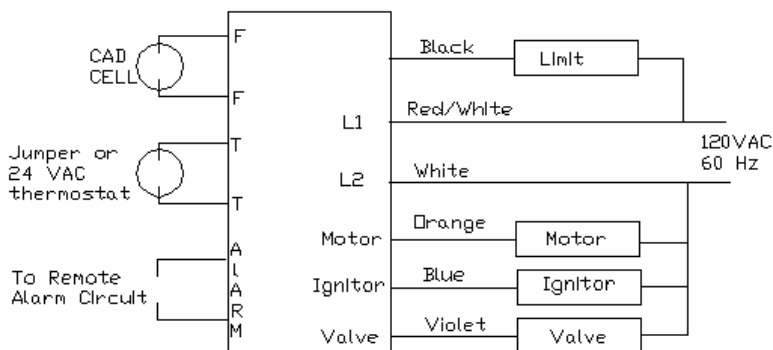
Fig. 4 Wiring Diagram – CCT with Motor Off Delay

Carlin 60200

Fig. 5 Wiring Diagram – Honeywell with Motor Off Delay

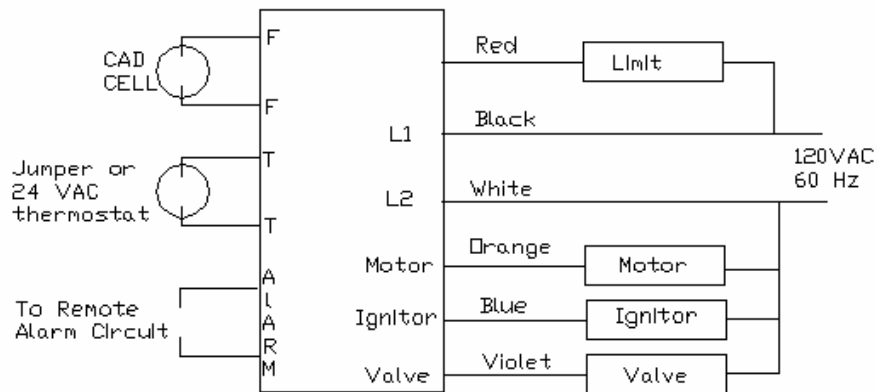

Honeywell R7184P

Fig. 6 Wiring Diagram – Low/High/Low Burner with CCT Control

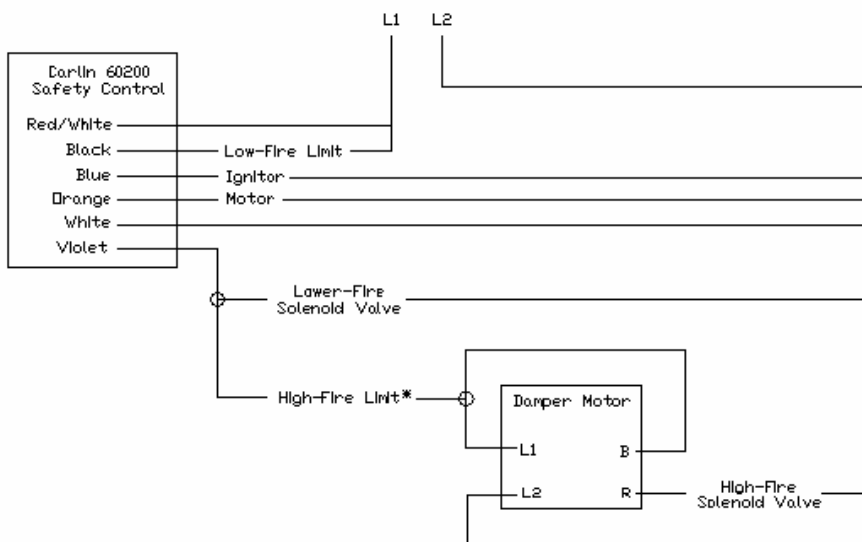
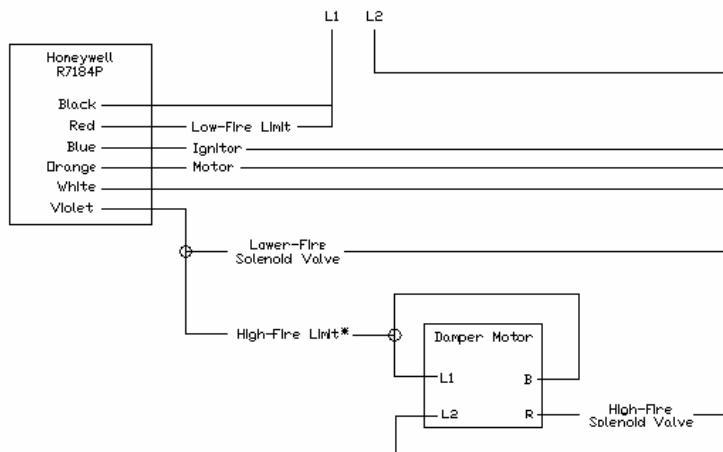
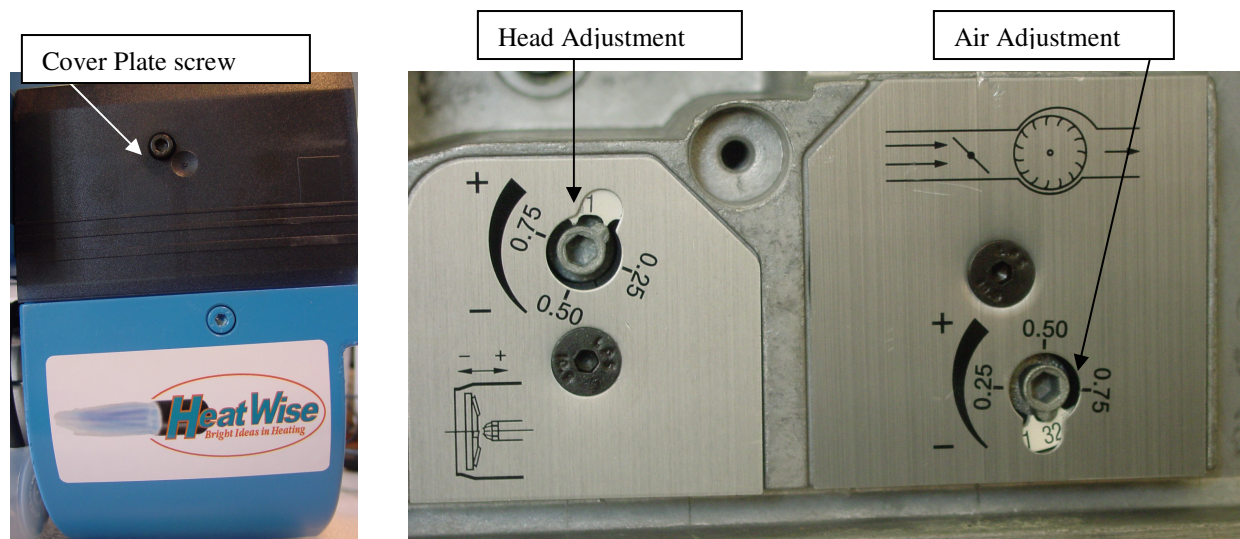

Fig. 7 Wiring Diagram– Low/High/Low Burner with Honeywell Control



3. FIRING HEAD ADJUSTMENT

Using the provided 4 mm allen key, remove the plastic cover plate to expose the air and head settings dial.



3.1 Graduations are numbered from 1 to 22 (1 to 20 on the Pioneer FV-burner) on the head adjustment dial (See Fig. 8). By turning the head adjustment screw *clockwise* (towards 22), the burner head will move inside the blast tube **AWAY** from the end cone. Pulling the head back achieves higher firing rates.

Fig. 8 Head Adjustment

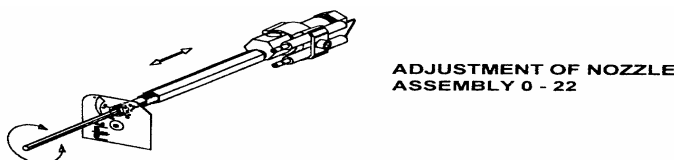

Similarly, by turning the head adjustment screw *counter-clockwise* (towards 1), the head will move forward inside the blast tube toward the end cone, decreasing the firing rate

4. AIR SHUTTER ADJUSTMENT

4.1 Graduations are numbered from 1 to 32 on the air adjustment dial (see Fig. 9). By turning the air adjustment screw clockwise, the air shutter opening increases. To achieve proper combustion, the air shutter may need to be adjusted so that combustion analysis achieves 11.5% to 13.5% CO₂ (or 3.5% to 5.0% O₂).

Fig. 9 Air Adjustment

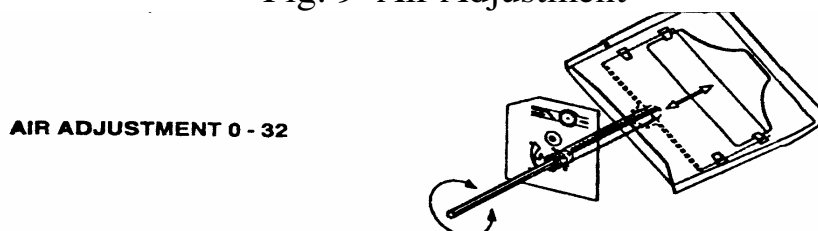

5. FUEL PUMP

5.1 A standard fuel pump is used on the Pioneer burner. Therefore, it is important that discharge pressure is monitored very closely. It is recommended that a 10~25 micron filter with a vacuum gauge be installed before the fuel pump using a flexible oil line (the flexible oil line is recommended to easily service the burner) between the fuel pump and filter. If a flexible oil line is not used, coil a copper oil line between the filter and pump to provide flexibility when changing the nozzle.

5.2 For most on/off burner operations, 100-PSI pressure can be used. For better performances it is recommended to adjust the pump 140 to 160 PSI, then, follow the flow chart to get the desired nozzle output capacity.

Model	Nozzle	Pump Pressure	Flow Rate GPH	Head	Air Shutter
P-1(FV)	0.50 X 80°B	150 PSI	0.57	9	7.75
P-1(FV)	0.30 X 80°B	200 PSI	0.50	7	0
P-1(KA)	0.85 X 80°B	160 PSI	1.03	3.5	1
P-1(KA)	0.75 X 80°B	180 PSI	0.92	1.5	11
P-2(KA)	1.00 X 80°B	150 PSI	1.22	6.5	3
P-2(KA)	0.85 X 80°B	160 PSI	1.03	3.5	1
P-2(KA)	0.85 X 80°B	140 PSI	1.02	4.5	0

6. COMMISSIONING THE BURNER

If the burner does not light because of excess air, then turn the air shutter half way to number 16. A smoke reading should then be taken. If the smoke number is higher than number 1, move the burner head forward by turning the head adjustment screw *counter-clockwise* or open the air shutter more by turning the air shutter screw *clockwise*. If smoke is zero, but O₂ is high and CO₂ is low, turn the burner head adjustment screw *clockwise* until O₂ is between 2% to 4%, and O₂ is between 13.5% and 11.5%.

RECORD THE READINGS:

DATE:

INSTALLER:

BURNER OPERATION: Record the Readings at Steady State	
Pressure over fire at steady state (should be +0.02 "W.C. to -0.02)*	
Draft in the Breech*	
Oil CO ₂ % = (11.5% to 13% CO ₂ or O ₂ % = (5.0% to 3.5%)	
Smoke Number	
Stack Temperature (300° F minimum, 550°F maximum)	
Carbon Monoxide (CO) in PPM (less than 100 PPM ideal; should not exceed 400 PPM Oxygen free)	
Head Setting	
Air Setting	
Pump Pressure	
Nozzle (GPH, Angle, Manufacturer and Type)	

* If the pressure over fire is positive, Heat Wise recommends wiring the burner with a motor off-delay.

** Draft readings may vary; consult the heat exchanger manufacturer for details on these values.



Troubleshooting Flow Chart for the Pioneer Oil Burner

